

TYPICAL ELEVATION WITH FASTENER SPACING

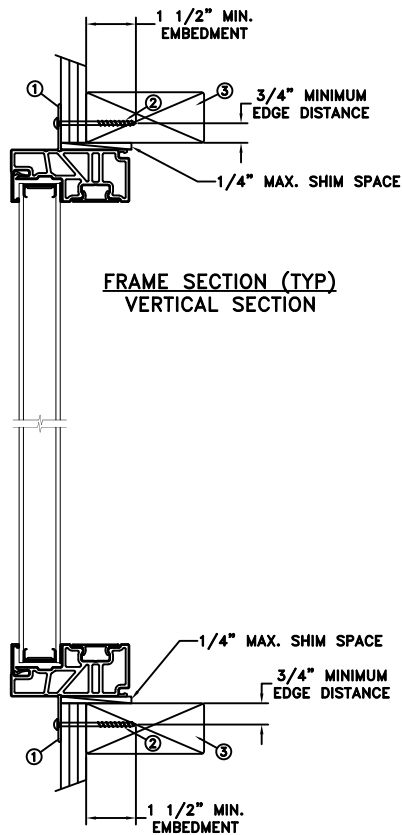

**FRAME SECTION (TYP)
VERTICAL SECTION**

**NAILFIN/WOOD
INSTALLATION**

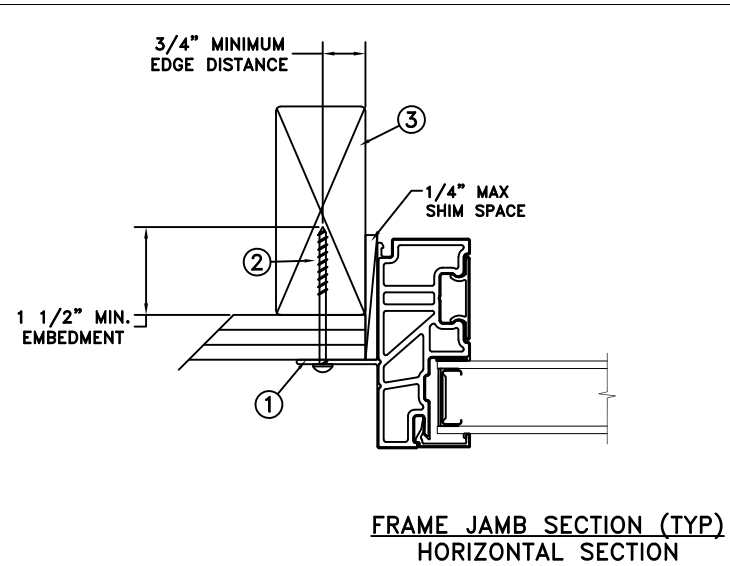

**FRAME JAMB SECTION (TYP)
HORIZONTAL SECTION**

| | | |
|----------------------|-----------|---------------|
| MAXIMUM FRAME | DP | IMPACT |
| 72" x 72" | +50/-55 | NO |

Installation Notes:

1. Seal flange/frame to substrate. Sill shall be set on a continuous serpentine bead of structural grade silicone caulk when no fastener is used to anchor the sill (typical).
2. Use #8 PH or greater fastener through the nailing flange with sufficient length to penetrate a minimum of 1 1/2" into the wood framing. For 2x wood frame substrate (min. S.G. = 0.42)
3. Host structure (wood buck, masonry, steel) to be designed and anchored to properly transfer all loads to the structure. The host structure is the responsibility of the architect or engineer of record for the project of installation.

General Notes:

1. The product shown herein is designed, tested and manufactured to comply with the wind load criteria of the adopted International Building Code (IBC), the International Residential Code (IRC), the current Florida Building Code (FBC) and the industry requirement for the stated conditions.
2. All glazing shall conform to ASTM E1300.
3. Use structural or composite shims where required.

This schedule addresses only the fasteners required to anchor the unit to achieve the rated design pressure and impact performance (where applicable) up to the size limitations noted. It is not intended as a guide to the installation process and does not address the sealing consideration that may arise in different wall conditions. For the complete installation procedure, see the instructions packaged with the unit or go to www.jeld-wen.com.

DISCLAIMER:

This drawing and its contents are confidential and are not to be reproduced or copied in whole or in part or used or disclosed to others except as authorized by JELD-WEN Inc.

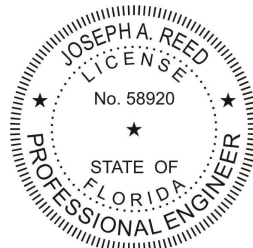

Joseph A. Reed

2020.04.07 13:55:33 -04'00'

JOSEPH A. REED, P.E.
 Florida P.E. No. 58920, REG. No. 33474
 5 Leigh Drive
 York, PA. 17406
 (717) 846-1200

| | | | |
|-------------------------------------|---|-----------|-----------------|
| DATE: 01/30/2020 | JELD-WEN 3737 LAKEPORT BLVD. KLAMATH FALLS OR, 97601 PHONE: (800) 535-3936 | | |
| SCALE: NTS | | | |
| DRAWN BY: J.HAWKINS | Auraline Composite Fixed Window | | |
| CHECKED BY: D.BELAU | | | |
| APPROVED BY: K.BATH | | | |
| RECORD No.: D015573 | | | |
| REPORT No.: NCTL-310-19-134 E0A0 | CAD DWG. No.: AuralineCompDS Cert | REV: A | SHEET 1 of 9 |

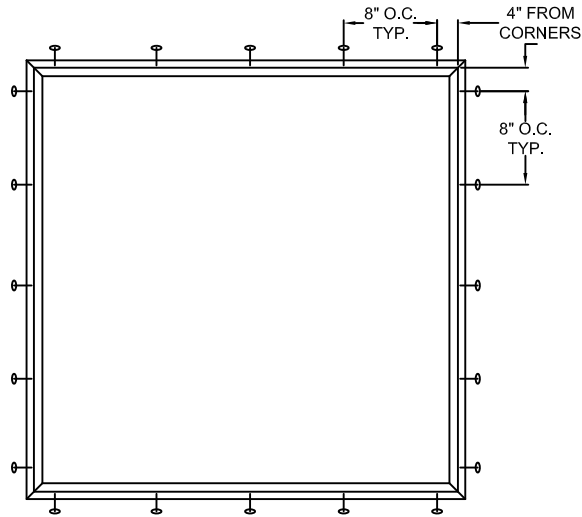

TYPICAL ELEVATION WITH FASTENER SPACING

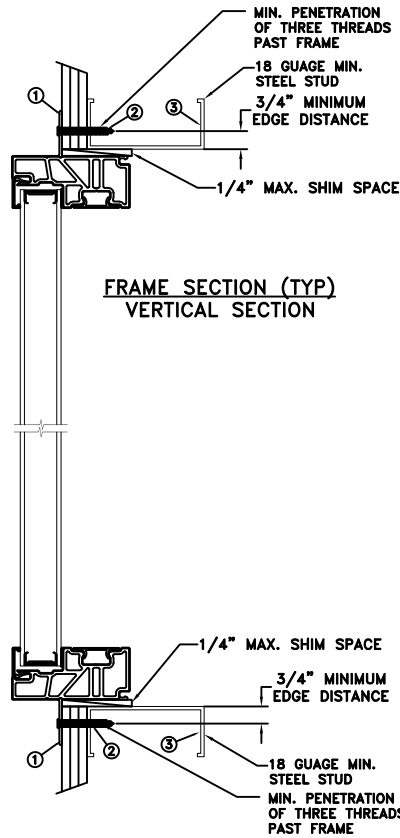

FRAME SECTION (TYP)
VERTICAL SECTION

NAILFIN/STEEL
INSTALLATION

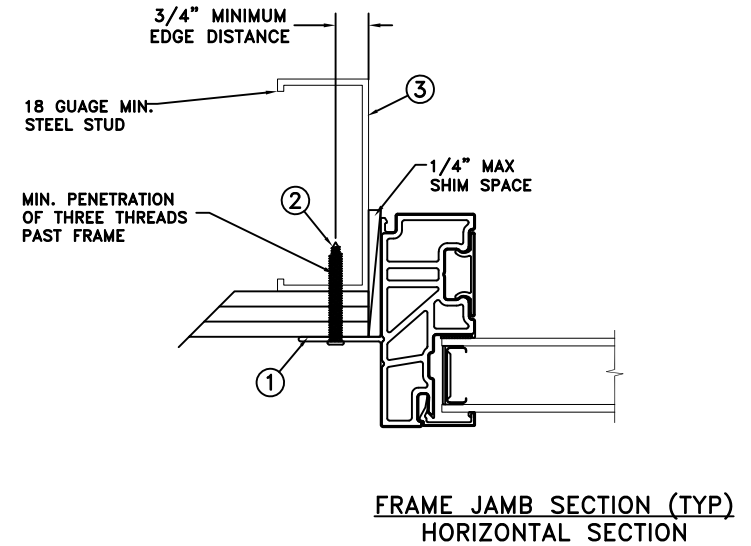

FRAME JAMB SECTION (TYP)
HORIZONTAL SECTION

| | | |
|---------------|---------|--------|
| MAXIMUM FRAME | DP | IMPACT |
| 72" x 72" | +50/-55 | NO |

Installation Notes:

1. Seal flange/frame to substrate. Sill shall be set on a continuous serpentine bead of structural grade silicone caulk when no fastener is used to anchor the sill (typical).
2. For anchoring through nailfin into metal framing use #10 TEK Self-Tapping screws with sufficient length to achieve a minimum penetration of three threads past the frame thickness. Steel substrate min. 18ga., $f_y = 33 \text{ ksi}$.
3. Host structure (wood buck, masonry, steel) to be designed and anchored to properly transfer all loads to the structure. The host structure is the responsibility of the architect or engineer of record for the project of installation.

General Notes:

1. The product shown herein is designed, tested and manufactured to comply with the wind load criteria of the adopted International Building Code (IBC), the International Residential Code (IRC), the current Florida Building Code (FBC) and the industry requirement for the stated conditions.
2. All glazing shall conform to ASTM E1300.
3. Use structural or composite shims where required.

This schedule addresses only the fasteners required to anchor the unit to achieve the rated design pressure and impact performance (where applicable) up to the size limitations noted. It is not intended as a guide to the installation process and does not address the sealing consideration that may arise in different wall conditions. For the complete installation procedure, see the instructions packaged with the unit or go to www.jeld-wen.com.

DISCLAIMER:

This drawing and its contents are confidential and are not to be reproduced or copied in whole or in part or used or disclosed to others except as authorized by JELD-WEN Inc.

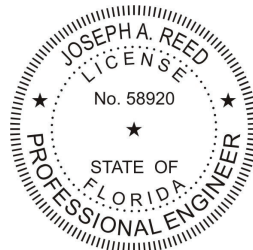

Joseph A. Reed

2020.04.07 13:55:33 -04'00'

JOSEPH A. REED, P.E.
Florida P.E. No. 58920, REG. No. 33474
5 Leigh Drive
York, PA. 17406
(717) 846-1200

| | | | |
|-------------------------------------|---|-----------|-----------------|
| DATE: 01/30/2020 | JELD WEN 3737 LAKEPORT BLVD. KLAMATH FALLS OR, 97601 PHONE: (800) 535-3936 | | |
| SCALE: NTS | | | |
| DRAWN BY: J.HAWKINS | Auraline Composite Fixed Window | | |
| CHECKED BY: D.BELAU | | | |
| APPROVED BY: K.BATH | | | |
| RECORD No.: D015573 | | | |
| REPORT No.: NCTL-310-19-134 E0A0 | CAD DWG. No.: AuralineCompDS Cert | REV: A | SHEET 2 of 9 |

**THROUGH FRAME
WOOD INSTALLATION**

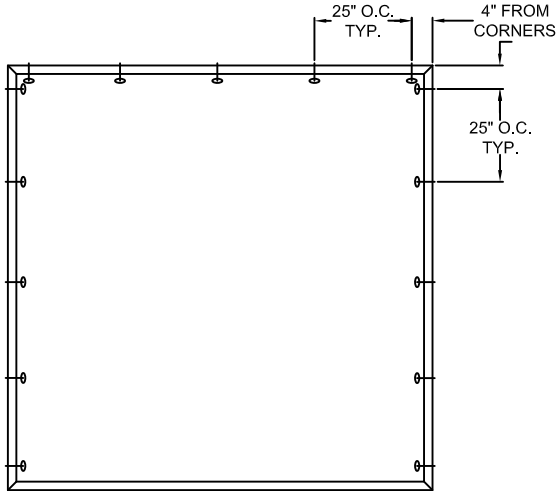

TYPICAL ELEVATION WITH FASTENER SPACING

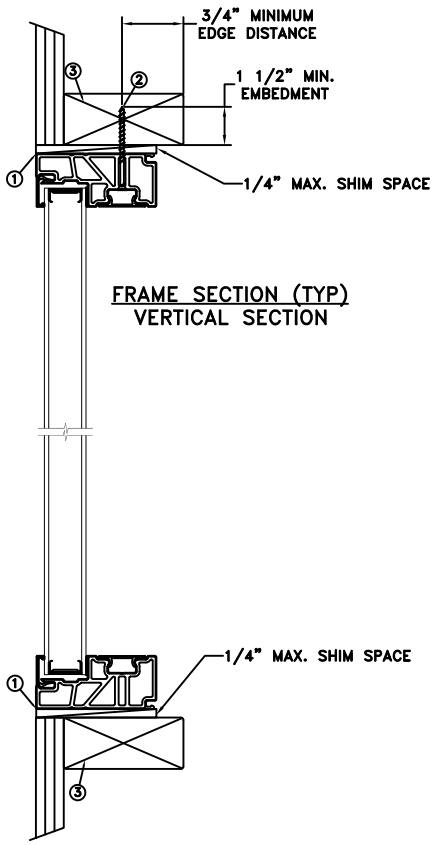

**FRAME SECTION (TYP)
VERTICAL SECTION**

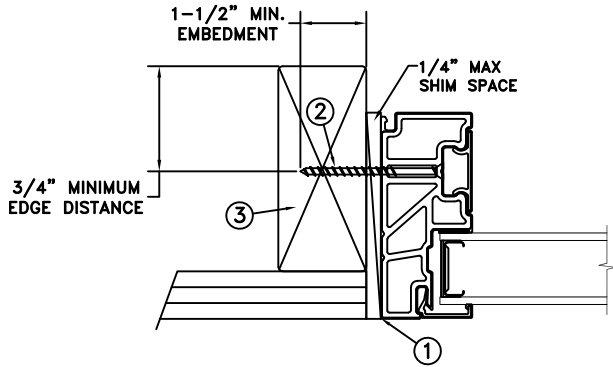

**FRAME JAMB SECTION (TYP)
HORIZONTAL SECTION**

| | | |
|----------------------|-----------|---------------|
| MAXIMUM FRAME | DP | IMPACT |
| 72" x 72" | +50/-55 | NO |

Installation Notes:

1. Seal flange/frame to substrate. Sill shall be set on a continuous serpentine bead of structural grade silicone caulk when no fasteners are used to anchor the sill (typical).
2. Use #8 PH or greater fastener through the head & side jambs with sufficient length to penetrate a minimum of 1 1/2" into the wood framing. For 2x wood frame substrate (min. S.G. = 0.42)
3. Host structure (wood buck, masonry, steel) to be designed and anchored to properly transfer all loads to the structure. The host structure is the responsibility of the architect or engineer of record for the project of installation.

General Notes:

1. The product shown herein is designed, tested and manufactured to comply with the wind load criteria of the adopted International Building Code (IBC), the International Residential Code (IRC), the current Florida Building Code (FBC) and the industry requirement for the stated conditions.
2. All glazing shall conform to ASTM E1300.
3. Use structural or composite shims where required.

This schedule addresses only the fasteners required to anchor the unit to achieve the rated design pressure and impact performance (where applicable) up to the size limitations noted. It is not intended as a guide to the installation process and does not address the sealing consideration that may arise in different wall conditions. For the complete installation procedure, see the instructions packaged with the unit or go to www.jeld-wen.com.

DISCLAIMER:
This drawing and its contents are confidential and are not to be reproduced or copied in whole or in part or used or disclosed to others except as authorized by JELD-WEN Inc.

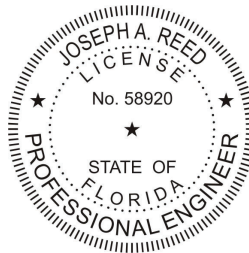

Joseph A. Reed

2020.04.07 13:55:33 -04'00'

JOSEPH A. REED, P.E.
Florida P.E. No. 58920, REG. No. 33474
5 Leigh Drive
York, PA. 17406
(717) 846-1200

| | |
|------------------------|--|
| DATE: 01/30/2020 | JELD WEN 3737 LAKEPORT BLVD. KLAMATH FALLS OR, 97601 PHONE: (800) 535-3936 |
| SCALE: NTS | |
| DRAWN BY: J.HAWKINS | Auraline Composite Fixed Window |
| CHECKED BY: D.BELAU | |
| APPROVED BY: K.BATH | |
| RECORD No.: D015573 | |
| REPORT No.: | CAD DWG. No.: AuralineCompDS Cert |
| | REV: A |
| | SHEET 3 of 9 |

**THROUGH FRAME
STEEL INSTALLATION**

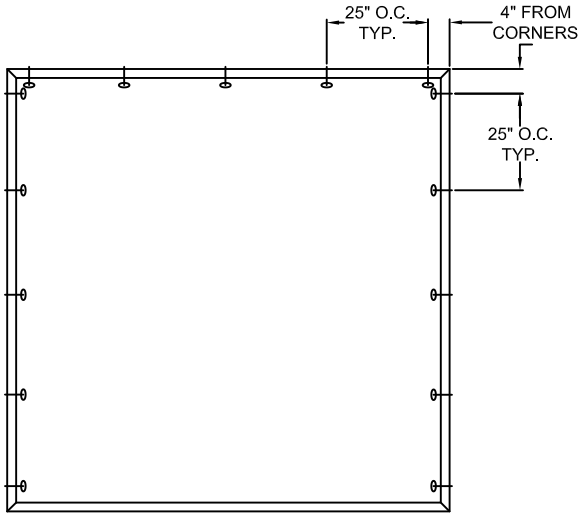

TYPICAL ELEVATION WITH FASTENER SPACING

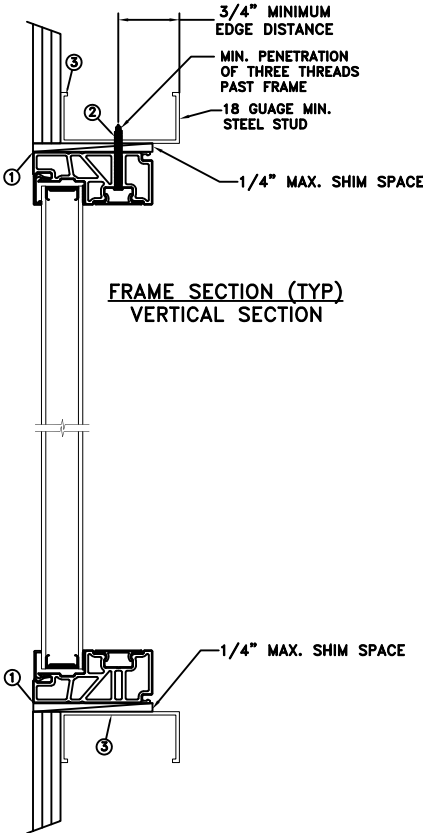

**FRAME SECTION (TYP)
VERTICAL SECTION**

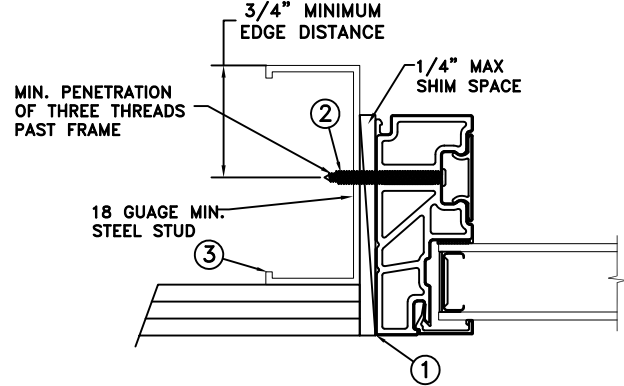

**FRAME JAMB SECTION (TYP)
HORIZONTAL SECTION**

| | | |
|----------------------|-----------|---------------|
| MAXIMUM FRAME | DP | IMPACT |
| 72" x 72" | +50/-55 | NO |

Installation Notes:

1. Seal flange/frame to substrate. Sill shall be set on a continuous serpentine bead of structural grade silicone caulk when no fastener is used to anchor the sill (typical).
2. For anchoring through head and side jamb into metal framing use #10 TEK Self-Tapping screws with sufficient length to achieve a minimum penetration of three threads past the frame thickness. Steel substrate min. 18ga., fy = 33 ksi.
3. Host structure (wood buck, masonry, steel) to be designed and anchored to properly transfer all loads to the structure. The host structure is the responsibility of the architect or engineer of record for the project of installation.

General Notes:

1. The product shown herein is designed, tested and manufactured to comply with the wind load criteria of the adopted International Building Code (IBC), the International Residential Code (IRC), the current Florida Building Code (FBC) and the industry requirement for the stated conditions.
2. All glazing shall conform to ASTM E1300.
3. Use structural or composite shims where required.

This schedule addresses only the fasteners required to anchor the unit to achieve the rated design pressure and impact performance (where applicable) up to the size limitations noted. It is not intended as a guide to the installation process and does not address the sealing consideration that may arise in different wall conditions. For the complete installation procedure, see the instructions packaged with the unit or go to www.jeld-wen.com.

DISCLAIMER:
This drawing and its contents are confidential and are not to be reproduced or copied in whole or in part or used or disclosed to others except as authorized by JELD-WEN Inc.

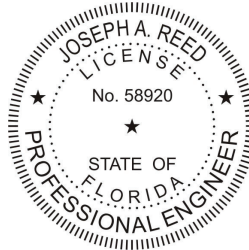

Joseph A. Reed

2020.04.07 13:55:33 -04'00'

JOSEPH A. REED, P.E.
Florida P.E. No. 58920, REG. No. 33474
5 Leigh Drive
York, PA. 17406
(717) 846-1200

| | |
|------------------------|---|
| DATE: 01/30/2020 | JELD-WEN 3737 LAKEPORT BLVD. KLAMATH FALLS OR, 97601 PHONE: (800) 535-3936 |
| SCALE: NTS | |
| DRAWN BY: J.HAWKINS | Auraline Composite Fixed Window |
| CHECKED BY: D.BELAU | |
| APPROVED BY: K.BATH | |
| RECORD No.: D015573 | |
| REPORT No.: | CAD DWG. No.: AuralineCompDS Cert |
| | REV: A |
| | SHEET 4 of 9 |

THROUGH FRAME
CONCRETE INSTALLATION

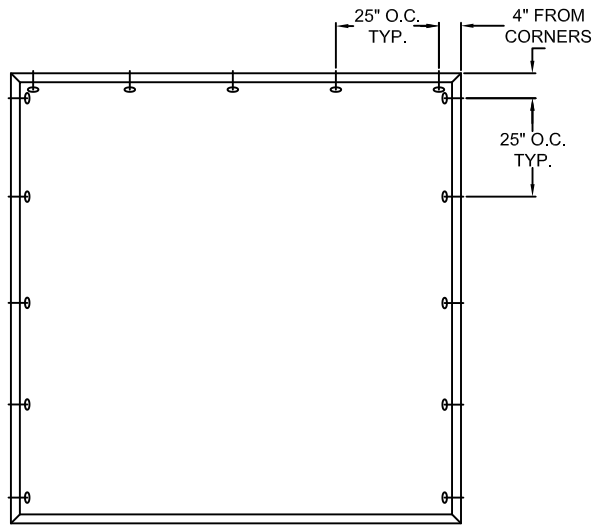

TYPICAL ELEVATION WITH FASTENER SPACING

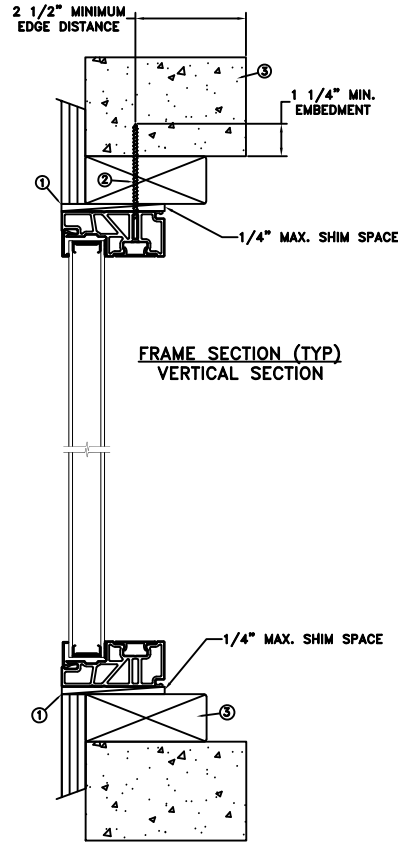

FRAME SECTION (TYP)
VERTICAL SECTION

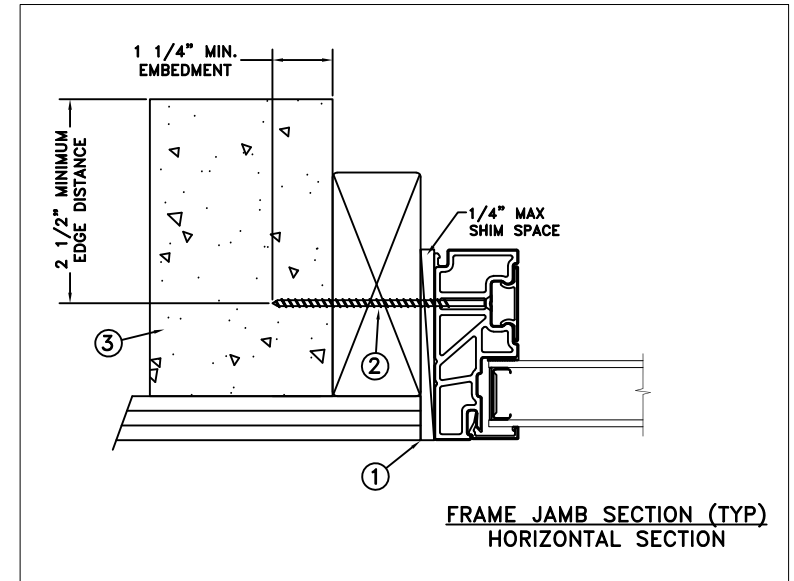

FRAME JAMB SECTION (TYP)
HORIZONTAL SECTION

| | | |
|---------------|---------|--------|
| MAXIMUM FRAME | DP | IMPACT |
| 72" x 72" | +50/-55 | NO |

Installation Notes:

1. Seal flange/frame to substrate. Sill shall be set on a continuous serpentine bead of structural grade silicone caulk when no fastener is used to anchor the sill (typical).
2. Use 3/16" Tapcon or equivalent fasteners through the head, sill and side jambs with sufficient length to penetrate a minimum of 1 1/4" into concrete or masonry at each location with a 2 1/2" min. from edge distance. For concrete (min. fc = 3000 psi) or masonry substrate (CMU shall be ASTM C90).
3. Host structure (wood buck, masonry, steel) to be designed and anchored to properly transfer all loads to the structure. The host structure is the responsibility of the architect or engineer of record for the project of installation.

General Notes:

1. The product shown herein is designed, tested and manufactured to comply with the wind load criteria of the adopted International Building Code (IBC), the International Residential Code (IRC), the current Florida Building Code (FBC) and the industry requirement for the stated conditions.
2. All glazing shall conform to ASTM E1300.
3. Use structural or composite shims where required.

This schedule addresses only the fasteners required to anchor the unit to achieve the rated design pressure and impact performance (where applicable) up to the size limitations noted. It is not intended as a guide to the installation process and does not address the sealing consideration that may arise in different wall conditions. For the complete installation procedure, see the instructions packaged with the unit or go to www.jeld-wen.com.

DISCLAIMER:

This drawing and its contents are confidential and are not to be reproduced or copied in whole or in part or used or disclosed to others except as authorized by JELD-WEN Inc.

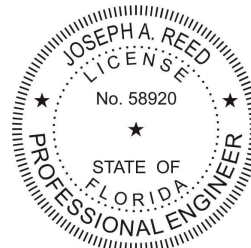

Joseph A. Reed

2020.04.07 13:55:33 -04'00'

JOSEPH A. REED, P.E.
Florida P.E. No. 58920, REG. No. 33474
5 Leigh Drive
York, PA. 17406
(717) 846-1200

| | | |
|------------------------|---|--|
| DATE: 01/30/2020 | 3737 LAKEPORT BLVD. KLAMATH FALLS OR, 97601 PHONE: (800) 535-3936 | |
| DRAWN BY: J.HAWKINS | SCALE: NTS | <p>Auraline Composite Fixed Window</p> |
| CHECKED BY: D.BELAU | TITLE: | |
| APPROVED BY: K.BATH | | |
| RECORD No.: D015573 | | |
| REPORT No.: | CAD DWG. No.: AuralineCompDS Cert | REV: A SHEET 5 of 9 |

MASONRY STRAP
WOOD/SCREW INSTALLATION

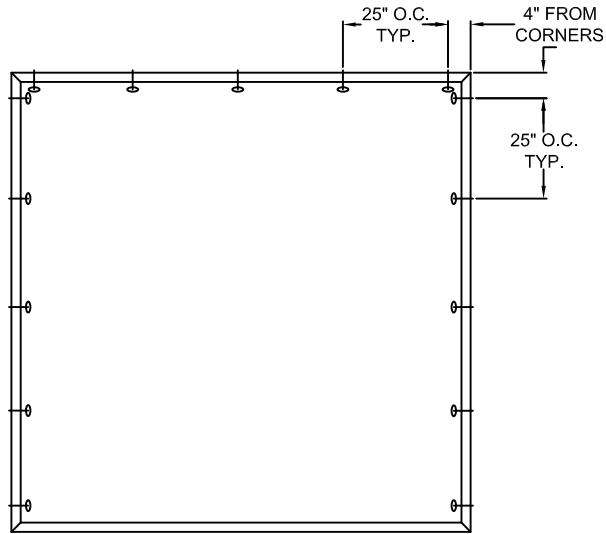

TYPICAL ELEVATION WITH FASTENER SPACING

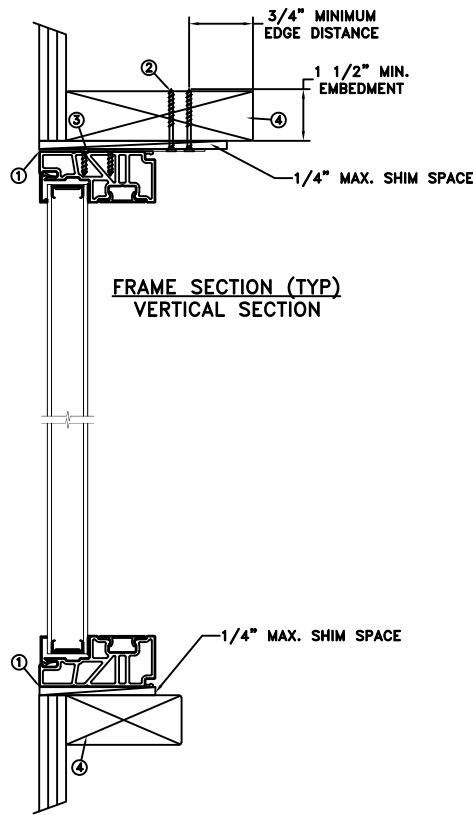

FRAME SECTION (TYP)
VERTICAL SECTION

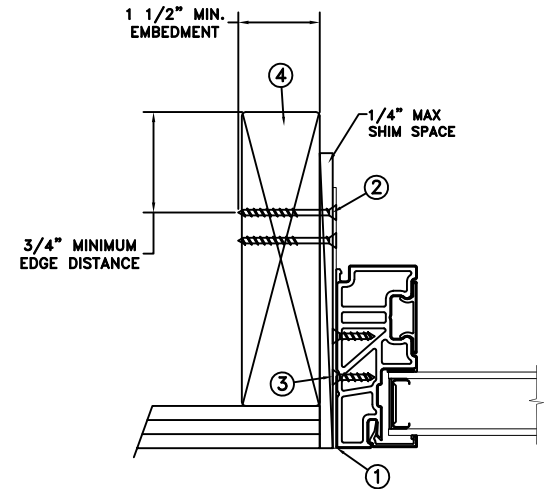

FRAME JAMB SECTION (TYP)
HORIZONTAL SECTION

| MAXIMUM FRAME | DP | IMPACT |
|---------------|---------|--------|
| 72" x 72" | +50/-55 | NO |

Installation Notes:

1. Seal flange/frame to substrate. Sill shall be set on a continuous serpentine bead of structural grade silicone caulk when no fastener is used to anchor the sill (typical).
2. Use 2 - #8 PFH or larger fasteners through masonry strap with sufficient length to penetrate a minimum of 1 1/2" into the buck. For 2x wood frame substrate (min. S.G. = 0.42).
3. Use 2 - #8 PFH or larger fasteners through masonry strap into jamb without penetrating through the jamb into product causing visibility or collateral damage to product.
4. Host structure (wood buck, masonry, steel) to be designed and anchored to properly transfer all loads to the structure. The host structure is the responsibility of the architect or engineer of record for the project of installation.

General Notes:

1. The product shown herein is designed, tested and manufactured to comply with the wind load criteria of the adopted International Building Code (IBC), the International Residential Code (IRC), the current Florida Building Code (FBC) and the industry requirement for the stated conditions.
2. All glazing shall conform to ASTM E1300.
3. Use structural or composite shims where required.

This schedule addresses only the fasteners required to anchor the unit to achieve the rated design pressure and impact performance (where applicable) up to the size limitations noted. It is not intended as a guide to the installation process and does not address the sealing consideration that may arise in different wall conditions. For the complete installation procedure, see the instructions packaged with the unit or go to www.jeld-wen.com.

DISCLAIMER:

This drawing and its contents are confidential and are not to be reproduced or copied in whole or in part or used or disclosed to others except as authorized by JELD-WEN Inc.

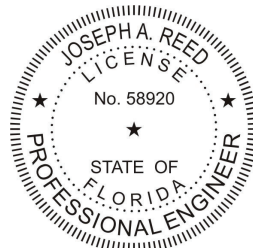

Joseph A. Reed

2020.04.07 13:55:33 -04'00'

JOSEPH A. REED, P.E.
Florida P.E. No. 58920, REG. No. 33474
5 Leigh Drive
York, PA. 17406
(717) 846-1200

| | | | |
|------------------------|--|---|--------------|
| | DATE: 01/30/2020 | JELD-WEN 3737 LAKEPORT BLVD. KLAMATH FALLS OR, 97601 PHONE: (800) 535-3936 | |
| DRAWN BY: J.HAWKINS | SCALE: NTS | | |
| CHECKED BY: D.BELAU | TITLE: Auraline Composite Fixed Window | | |
| APPROVED BY: K.BATH | | | |
| RECORD No.: D015573 | | | |
| REPORT No.: | CAD DWG. No.: AuralineCompDS Cert | REV: A | SHEET 6 of 9 |

MASONRY STRAP
WOOD/NAIL INSTALLATION

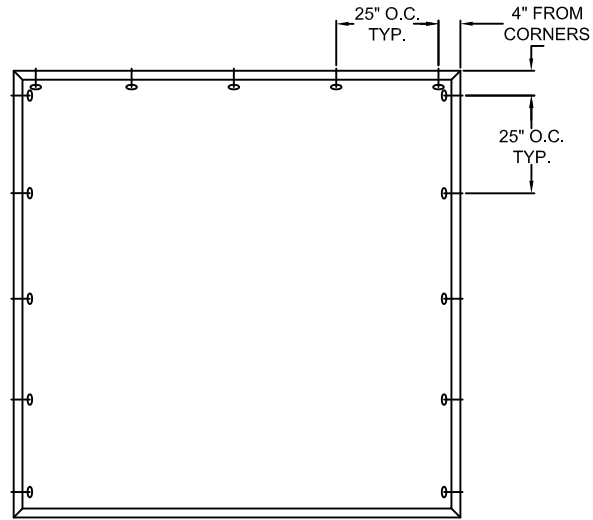

TYPICAL ELEVATION WITH FASTENER SPACING

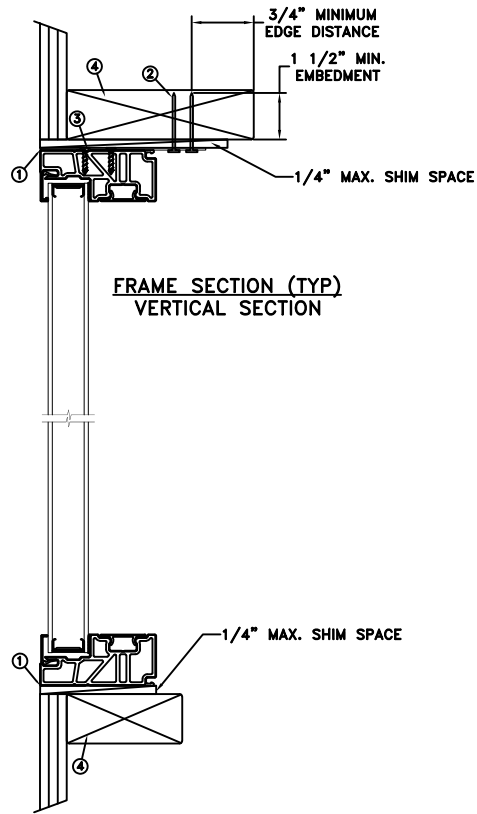

FRAME SECTION (TYP)
VERTICAL SECTION

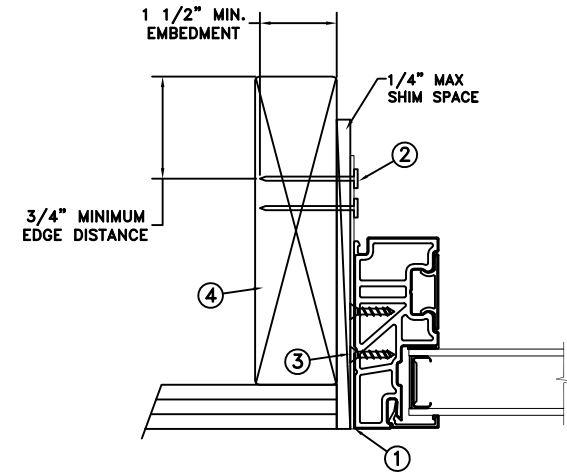

FRAME JAMB SECTION (TYP)
HORIZONTAL SECTION

| | | |
|---------------|---------|--------|
| MAXIMUM FRAME | DP | IMPACT |
| 72" x 72" | +50/-55 | NO |

Installation Notes:

1. Seal flange/frame to substrate. Sill shall be set on a continuous serpentine bead of structural grade silicone caulk when no fastener is used to anchor the sill (typical).
2. Use 2 - 6d x 2" fasteners through masonry strap with sufficient length to penetrate a minimum of 1 1/2" into the buck. For 2x wood frame substrate (min. S.G. = 0.42).
3. Use 2 - #8 PFH or larger fasteners through masonry strap into jamb without penetrating through the jamb into product causing visibility or collateral damage to product.
4. Host structure (wood buck, masonry, steel) to be designed and anchored to properly transfer all loads to the structure. The host structure is the responsibility of the architect or engineer of record for the project of installation.

General Notes:

1. The product shown herein is designed, tested and manufactured to comply with the wind load criteria of the adopted International Building Code (IBC), the International Residential Code (IRC), the current Florida Building Code (FBC) and the industry requirement for the stated conditions.
2. All glazing shall conform to ASTM E1300.
3. Use structural or composite shims where required.

This schedule addresses only the fasteners required to anchor the unit to achieve the rated design pressure and impact performance (where applicable) up to the size limitations noted. It is not intended as a guide to the installation process and does not address the sealing consideration that may arise in different wall conditions. For the complete installation procedure, see the instructions packaged with the unit or go to www.jeld-wen.com.

DISCLAIMER:

This drawing and its contents are confidential and are not to be reproduced or copied in whole or in part or used or disclosed to others except as authorized by JELD-WEN Inc.

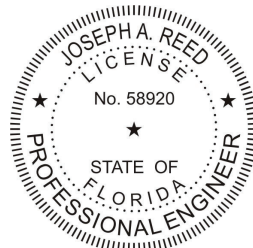

Joseph A. Reed

2020.04.07 13:55:33 -04'00'

JOSEPH A. REED, P.E.
Florida P.E. No. 58920, REG. No. 33474
5 Leigh Drive
York, PA. 17406
(717) 846-1200

| | | |
|------------------------|---|---|
| DATE: 01/30/2020 | | 3737 LAKEPORT BLVD. KLAMATH FALLS OR, 97601 PHONE: (800) 535-3936 |
| DRAWN BY: J.HAWKINS | | SCALE: NTS |
| CHECKED BY: D.BELAU | TITLE: Auraline Composite Fixed Window | |
| APPROVED BY: K.BATH | RECORD No.: D015573 | |
| REPORT No.: | CAD DWG. No.: AuralineCompDS Cert | REV: A SHEET 7 of 9 |

MASONRY STRAP
STEEL/SCREW INSTALLATION

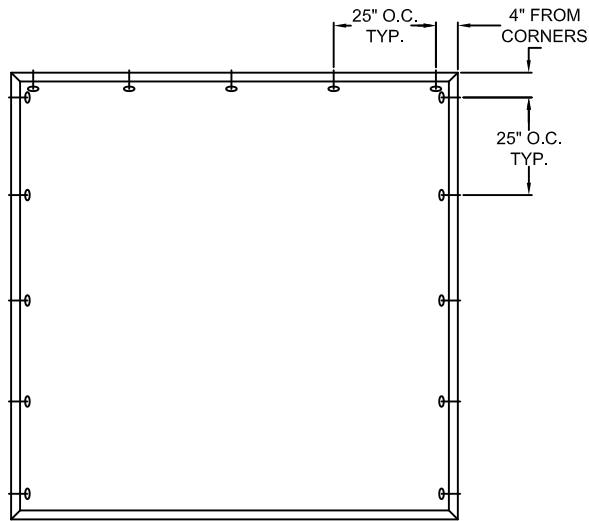

TYPICAL ELEVATION WITH FASTENER SPACING

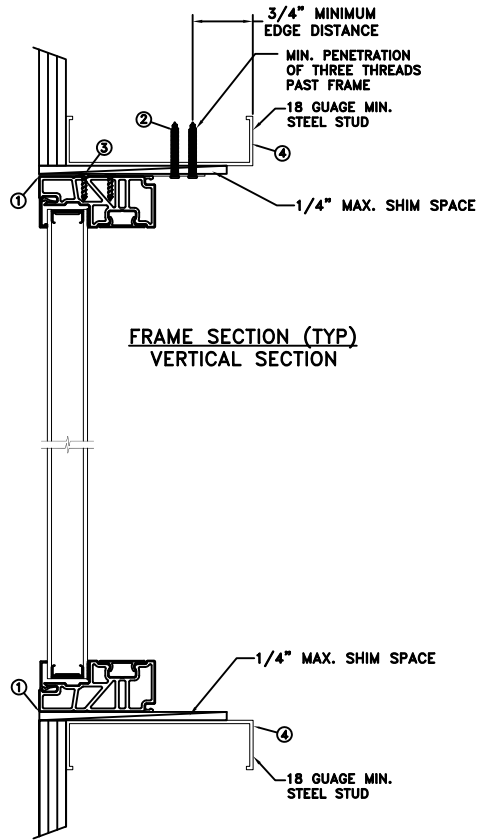

FRAME SECTION (TYP)
VERTICAL SECTION

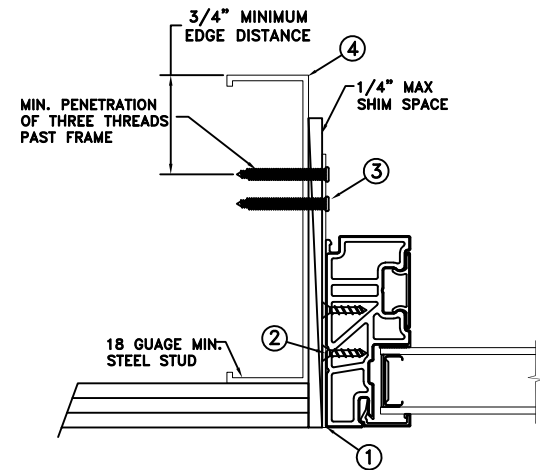

FRAME JAMB SECTION (TYP)
HORIZONTAL SECTION

| MAXIMUM FRAME | DP | IMPACT |
|---------------|---------|--------|
| 72" x 72" | +50/-55 | NO |

Installation Notes:

1. Seal flange/frame to substrate. Sill shall be set on a continuous serpentine bead of structural grade silicone caulk when no fastener is used to anchor the sill (typical).
2. Use 2 - #10 TEK Self-Tapping or larger screws through masonry strap with sufficient length to achieve a minimum penetration of three threads past the frame thickness. Steel substrate min. 18ga., fy = 33 ksi.
3. Use 2 - #8 PFH or larger fasteners through masonry strap into jamb without penetrating through the jamb into product causing visibility or collateral damage to product.
4. Host structure (wood buck, masonry, steel) to be designed and anchored to properly transfer all loads to the structure. The host structure is the responsibility of the architect or engineer of record for the project of installation.

General Notes:

1. The product shown herein is designed, tested and manufactured to comply with the wind load criteria of the adopted International Building Code (IBC), the International Residential Code (IRC), the current Florida Building Code (FBC) and the industry requirement for the stated conditions.
2. All glazing shall conform to ASTM E1300.
3. Use structural or composite shims where required.

This schedule addresses only the fasteners required to anchor the unit to achieve the rated design pressure and impact performance (where applicable) up to the size limitations noted. It is not intended as a guide to the installation process and does not address the sealing consideration that may arise in different wall conditions. For the complete installation procedure, see the instructions packaged with the unit or go to www.jeld-wen.com.

DISCLAIMER:

This drawing and its contents are confidential and are not to be reproduced or copied in whole or in part or used or disclosed to others except as authorized by JELD-WEN Inc.

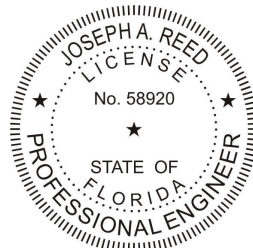

Joseph A. Reed

2020.04.07 13:55:33 -04'00'

JOSEPH A. REED, P.E.
Florida P.E. No. 58920, REG. No. 33474
5 Leigh Drive
York, PA. 17406
(717) 846-1200

| | | |
|------------------------|---|---|
| DATE: 01/30/2020 | | 3737 LAKEPORT BLVD. KLAMATH FALLS OR, 97601 PHONE: (800) 535-3936 |
| DRAWN BY: J.HAWKINS | | SCALE: NTS |
| CHECKED BY: D.BELAU | TITLE: Auraline Composite Fixed Window | |
| APPROVED BY: K.BATH | RECORD No.: D015573 | |
| REPORT No.: | CAD DWG. No.: AuralineCompDS Cert | REV: A SHEET 8 of 9 |

MASONRY STRAP CONCRETE
SCREW INSTALLATION

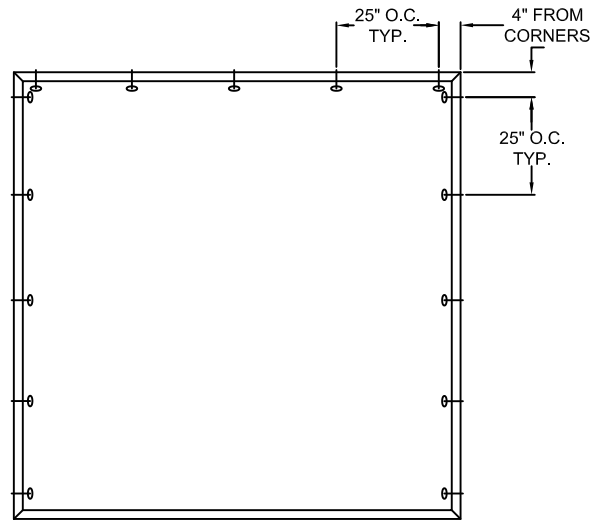

TYPICAL ELEVATION WITH FASTENER SPACING

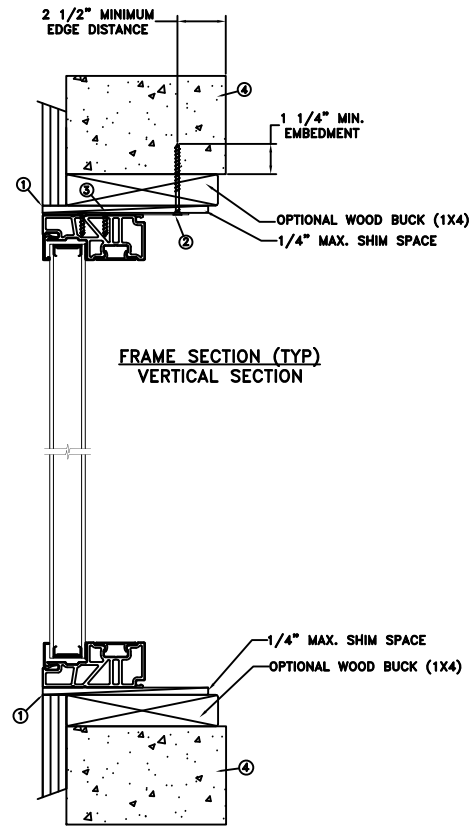

FRAME SECTION (TYP)
VERTICAL SECTION

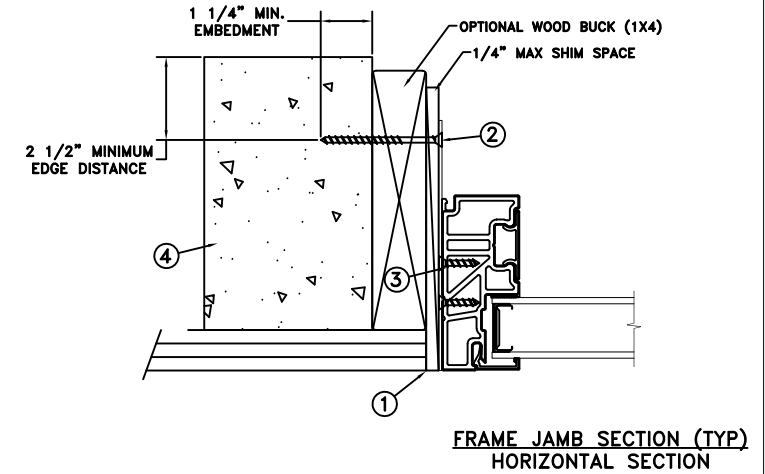

FRAME JAMB SECTION (TYP)
HORIZONTAL SECTION

| | | |
|---------------|---------|--------|
| MAXIMUM FRAME | DP | IMPACT |
| 72" x 72" | +50/-55 | NO |

Installation Notes:

1. Seal flange/frame to substrate. Sill shall be set on a continuous serpentine bead of structural grade silicone caulk when no fastener is used to anchor the sill (typical).
2. Use 1 - 3/16" Tapcon or equivalent fasteners through masonry strap with sufficient length to penetrate a minimum of 1 1/4" into the buck or concrete. For 2x wood frame substrate (min. S.G. = 0.42). For concrete (min. fc = 3000 psi) or masonry substrate (CMU shall be ASTM C90).
3. Use 2 - #8 PFH or larger fasteners through masonry strap into jamb without penetrating through the jamb into product causing visibility or collateral damage to product.
4. Host structure (wood buck, masonry, steel) to be designed and anchored to properly transfer all loads to the structure. The host structure is the responsibility of the architect or engineer of record for the project of installation.

General Notes:

1. The product shown herein is designed, tested and manufactured to comply with the wind load criteria of the adopted International Building Code (IBC), the International Residential Code (IRC), the current Florida Building Code (FBC) and the industry requirement for the stated conditions.
2. All glazing shall conform to ASTM E1300.
3. Use structural or composite shims where required.

This schedule addresses only the fasteners required to anchor the unit to achieve the rated design pressure and impact performance (where applicable) up to the size limitations noted. It is not intended as a guide to the installation process and does not address the sealing consideration that may arise in different wall conditions. For the complete installation procedure, see the instructions packaged with the unit or go to www.jeld-wen.com.

DISCLAIMER:

This drawing and its contents are confidential and are not to be reproduced or copied in whole or in part or used or disclosed to others except as authorized by JELD-WEN Inc.

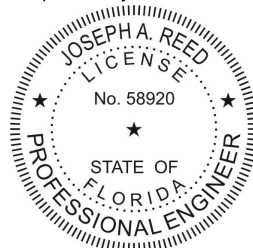

Joseph A. Reed

2020.04.07 13:55:33 -04'00'

JOSEPH A. REED, P.E.
Florida P.E. No. 58920, REG. No. 33474
5 Leigh Drive
York, PA. 17406
(717) 846-1200

| | | |
|------------------------|---|---|
| DATE: 01/30/2020 | | 3737 LAKEPORT BLVD. KLAMATH FALLS OR, 97601 PHONE: (800) 535-3936 |
| DRAWN BY: J.HAWKINS | | SCALE: NTS |
| CHECKED BY: D.BELAU | TITLE: Auraline Composite Fixed Window | |
| APPROVED BY: K.BATH | RECORD No.: D015573 | |
| REPORT No.: | CAD DWG. No.: AuralineCompDS Cert | REV: A SHEET 9 of 9 |